

## SFP+-10G-SR85-03

### 10Gb/s 850nm SFP+ Transceiver

#### 1. Feature:

- SFP+ package with LC connector
- 850nm VCSEL Laser and PIN photo detector
- Up to 300m transmission on 2000MHz-km MMF
- Up to 11.3Gbps Data Links
- Power dissipation < 1W
- LVPECL compatible data input/output interface
- Low EMI and excellent ESD protection
- laser safety standard IEC-60825 compliant
- Compatible with RoHS
- Compatible with SFF8472



#### 2. Application

- 10GBASE-SR/SW 10G Ethernet
- 1200-Mx-SN-I 10G Fibre Channel

#### 3. Absolute Maximum Ratings

Parameter	Symbol	Minimum	Maximum	Units
Storage Temperature	Tst	-40	+85	°C
Supply Voltage	Vcc	0	+3.6	V
Operating Relative Humidity	RH	0	85	%

## 4. Operation Environment

Parameter	Symbol	Min	Typical	Max	Units
Supply Voltage	Vcc	3.15		3.45	V
Operating Case Temperature	Tc	0		+70	°C
Power Dissipation				1	W
Data Rate			10.3125		Gbps

## 5. Optical Characteristics

(Ambient Operating Temperature 0°C to +70°C, Vcc =3.3 V)

Parameter	Symbol	Min.	Typ.	Max.	Units
<b>Transmitter Section</b>					
Center Wavelength	$\lambda_o$	840	850	860	nm
RMS Spectral Width	$\Delta\lambda$	-	-	0.45	dB
Average Output Power	Po	-5	-	0	dBm
Extinction Ratio	Er	3.0	-	-	dB
Dispersion Penalty				3.9	dB
Relative Intensity Noise	RIN <sub>12</sub> OMA			-128	dB/Hz
Total jitter	Tj	IEEE 802.3ae			
<b>Receiver Section</b>					
Center Wavelength	$\lambda_o$		850		nm
Receiver Sensitivity	Rsen			-11.5	dBm
Stressed Sensitivity	Rsen			-10.5	dBm
Receiver Overload	Rov	0			dBm
Return Loss		12			dB
LOS Assert	LOS <sub>A</sub>	-25			dBm
LOS Dessert	LOS <sub>D</sub>			-13	dBm
LOS Hysteresis		0.5		4	

## 6. Electrical Characteristics

(Ambient Operating Temperature 0°C to +70°C, Vcc =3.3 V)

Parameter	Symbol	Min.	Typ.	Max.	unit
<b>Transmitter Section</b>					
Input Differential Impedence	Zin	90	100	110	Ohm
Data Input Swing Differential	Vin	180		700	mV
TX Disable	Disable	2.0		Vcc	V
	Enable	0		0.8	V
TX Fault	Assert	2.0		Vcc	V
	Deassert	0		0.8	V
<b>Receiver Section</b>					
Output differential impedence	Zout		100		Ohm
Data output Swing Differential	Vout	300		800	mV
Rx_LOS	Assert	2.0		Vcc	V
	Deassert	0		0.8	V

## 7. Maximum Supported Distances

Parameter	Symbol	Min.	Typ.	Max.	unit
Fiber Type	850nm OFL BandWidth				
62.5 um	160MHz-km			26	m
	200MHz-km			33	m
50 um	400MHz-km			66	m
	500MHz-km			82	m
	2000MHz-km			300	m

## 8. Diagnostics

Parameter	Range	Accuracy	Unit	Calibration
Temperature	0 ~ 70	±5	℃	Internal
Voltage	3.15 ~ 3.45	0.1	V	Internal
Bias Current	2 ~ 12	±2	mA	Internal
Tx Power	-8 ~ 1	±2	dBm	Internal
Rx Power	-18 ~ -3	±3	dBm	Internal

## 9. EEPROM INFORMATION (A0) :

Addr	Field Size (Bytes)	Name of Field	HEX	Description
0	1	Identifier	03	SFP
1	1	Ext. Identifier	04	MOD4
2	1	Connector	07	LC
3-10	8	Transceiver	10 00 00 00 00 00 00 00	Transmitter Code
11	1	Encoding	06	64B66B
12	1	BR, nominal	67	1000M bps
13	1	Reserved	00	
14	1	Length (9um)-km	00	
15	1	Length (9um)	00	
16	1	Length (50um)	08	
17	1	Length (62.5um)	02	
18	1	Length (copper)	00	
19	1	Reserved	00	
20-35	16	Vendor name	57 49 4E 54 4F 50 20 20 20 20 20 20 20 20 20 20	
36	1	Reserved	00	
37-39	3	Vendor OUI	00 00 00	
40-55	16	Vendor PN	xx xx xx xx xx xx xx xx xx xx xx xx xx xx xx xx	ASC II
56-59	4	Vendor rev	31 2E 30 20	V1.0
60-61	2	Wavelength	03 52	850nm
62	1	Reserved	00	
63	1	CC BASE	XX	Check sum of byte 0~62
64-65	2	Options	00 1A	LOS, TX_DISABLE, TX_FAULT

66	1	BR, max	00	
67	1	BR, min	00	
68-83	16	Vendor SN	00 00 00 00 00 00 00 00 00 00 00 00 00 00 00 00	Unspecified
84-91	8	Vendor date code	XX XX XX 20	Year, Month, Day
92-94	3	Reserved	00	
95	1	CC_EXT	XX	Check sum of byte 64~94
96-255	160	Vendor specific		

## 10. Pin Description:

Pins	Name	Discription	NOTE
1	VeeT	Transmitter Ground	
2	Tx Fault	Transmitter Fault Indication	1
3	Tx Disable	Transmitter Disable	2
4	MOD DEF2	Module Definition 2	3
5	MOD DEF1	Module Definition 1	3
6	MOD DEF0	Module Definition 0	3
7	RS0	Not Connected	
8	LOS	Loss of Signal	4
9	RS1	Not Connected	
10	VeeR	Receiver Ground	
11	VeeR	Receiver Ground	
12	RD-	Inv. Received Data Output	5
13	RD+	IReceived Data Output	5
14	VeeR	Receiver Ground	
15	VccR	Receiver Power	
16	VccT	Transmitter Power	
17	VeeT	Transmitter Ground	
18	TD+	Transmit Data Input	6
19	TD-	Inv. Transmit Data Input	6
20	VeeT	Transmitter Ground	

### Notes:

1. TX Fault is an open collector output, which should be pulled up with a 4.7k~10kΩ resistor on the host board to a voltage between 2.0V and Vcc+0.3V. Logic 0 indicates normal operation; logic 1 indicates a laser fault of some kind. In the low state, the output will be

- pulled to less than 0.8V.
2. TX Disable is an input that is used to shut down the transmitter optical output. It is pulled up within the module with a 4.7k~10kΩ resistor. Its states are:  
Low (0~0.8V): Transmitter on  
(>0.8V, <2.0V): Undefined  
High (2.0~3.465V): Transmitter Disabled  
Open: Transmitter Disabled
  3. MOD-DEF 0,1,2 are the module definition pins. They should be pulled up with a 4.7k~10kΩ resistor on the host board. The pull-up voltage shall be VccT or VccR.  
MOD-DEF 0 is grounded by the module to indicate that the module is present  
MOD-DEF 1 is the clock line of two wire serial interface for serial ID  
MOD-DEF 2 is the data line of two wire serial interface for serial ID
  4. LOS is an open collector output, which should be pulled up with a 4.7k~10kΩ resistor on the host board to a voltage between 2.0V and Vcc+0.3V. Logic 0 indicates normal operation; logic 1 indicates loss of signal. In the low state, the output will be pulled to less than 0.8V.
  5. These are the differential receiver output. They are internally AC-coupled 100Ω differential lines which should be terminated with 100Ω (differential) at the user SERDES.
  6. These are the differential transmitter inputs. They are AC-coupled, differential lines with 100Ω differential termination inside the module.

### 11. Recommended Application Circuit

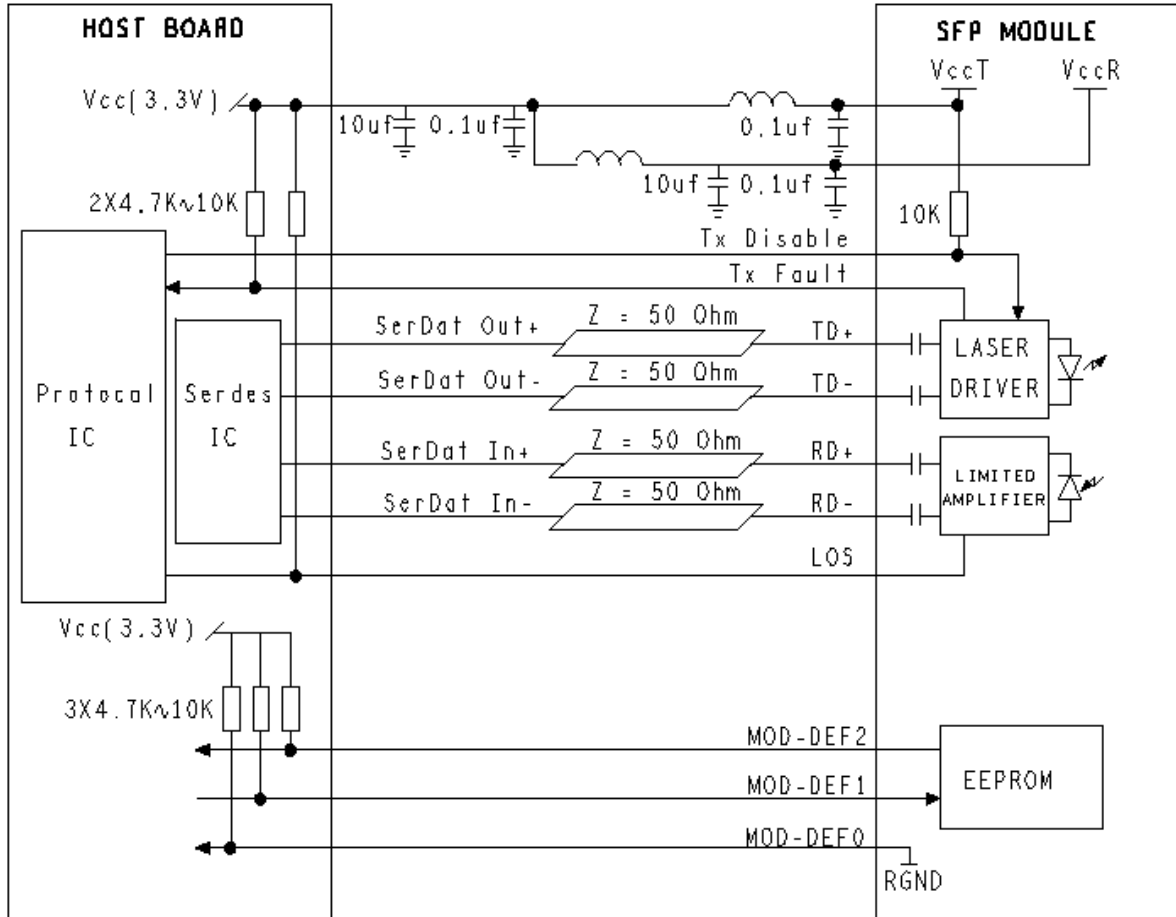

## 12. Outline Dimensions (mm)

