



All ports PoE+ with up to 280W/380W PoE budget and Remote Management option
Select your new network engine!

As a leading provider of network equipment for SMBs, Benchu group understands the importance of providing a great choice of PoE port counts and power budgets that can adapt to your business' needs, whether in the hospitality, catering, education or retail domains.

The SP7500-16PGE4GC-L2M Gigabit Ethernet Switches with PoE+ and 4 SFP Ports join the Benchu group Standalone Smart Switches family, adding full 16 port PoE+

support for deployment of modern high-power PoE devices. Cautious spender organizations can now deploy denser PoE+ devices connected to a cost-effective switch, with a reasonable PoE power budget of 280W over 16-port. Organizations who buy infrastructure for the long term and want future proofing for the unforeseeable can now select a switch with a PoE power budget of 380W

Support 4 Ports 1Gb SFP Uplink , provides greater bandwidth and powerful processing capacity. It offers a maximum 4Gbps uplink bandwidth through the Four 1Gbps SFP ports. In addition, the administrator can flexibly choose the suitable (1.25G) SFP transceiver according to the transmission distance required to extend the network efficiently.

Highlights

The Benchu group SP7500-16PGE4GC-L2M PoE+ Gigabit Smart Switches with Remote Management provides a great value, with configurable L2 network features like VLANs and PoE operation scheduling, allowing SMB customers to deploy PoE-based VoIP phones, IP cameras, video-over-IP endpoints and Wireless access points simply and securely. Advanced features such as IPv4/IPv6 Layer 3 static routing, LACP link aggregation, ERPS, DHCP, DiffServ QoS, Private VLANs, Multicast VLAN and Spanning Tree will satisfy even the most advanced small business networks.



Key features include:

- Layer 3 static routing (IPv4 and IPv6)
- Advanced VLAN and Private VLAN support for better network segmentation
- L2/L3/L4 access control lists (ACLs) for granular network access control including 802.1x port authentication
- Advanced per port PoE controls for remote power management of PoE connected devices including operation scheduling (e.g. Wireless APs, IP security cameras, LED lighting, secure access door locks, IoT devices...)
- Advanced QoS (Quality of Service) for traffic prioritization including port-based, 802.1p and L2/L3/L4 DSCP-based
- IGMP Snooping and Querier for multicast optimization
- Dynamic ARP for increased security targeting a class of Man in the Middle attack
- Rate limiting and priority queuing for better bandwidth allocation
- Port mirroring for network monitoring
- Energy Efficient Ethernet (IEEE 802.3az) for maximum power savings
- SNMP v1, v2c and RMON remote monitoring

Build a future-proof network with BENCHU:

- Solid performance with non-blocking architecture, 8K MAC addresses, 100 shared (ingress) ACLs and 512 Multicast groups
- Comprehensive IPv6 supporting management, QoS, ACL and routing, ensuring investment protection and a smooth migration to IPv6-based network
- PoE+ support on all models and on all ports
- 4 Dedicated SFPs, not only providing fiber uplinks, but also uplink redundancy and failover, improving reliability and availability for the network

Fast Access

- The remote units provide the full line-speed forwarding capability. All ports support non-blocking data packet forwarding, providing users with high-speed access experience and meeting the requirements of high-bandwidth services such as HD video conferencing, online video, and large file download.

Powerful Network Security

- The SP7500 Series offers comprehensive Layer 2 to Layer 4 Access Control List (ACL) for enforcing security to the edge. It can be used to restrict network access by denying packets based on source and destination IP address, TCP/UDP ports or defined typical network applications. Its protection mechanism also comprises 802.1X Port-based and MAC-based user and device authentication.

BENCHU Quality and Reliability

- Low power consumption, fanless, high-strength metal casing.
- high redundancy design, providing a long term and stable PoE power output.
- CE, FCC, RoHS, CB.
- The user-friendly panel can show the device status through the LED indicator of PWR, Link.

Easy operation and maintenance management

- Web management, CLI command line (Console, Telnet), SNMP (V1/V2/V3).
- HTTPS, and SSHV1/V2.
- RMON, system log, LLDP, and port traffic statistics.
- CPU monitoring, memory monitoring, Ping test, and cable diagnose.



Hardware at a Glance

FRONT				REAR	SIDE
Model Name	10/100/1000Base-T RJ45 ports	1GBASE-X Fiber SFP Ports	PoE+ 802.3at Ports (Budget)	Power Supply	Fans
SP7500-16PGE4GC-L2M	20	4	16 PoE+ (280W)	1 internal PSU, fixed	2
SP7500-16PGE4GC-400W-L2M	20	4	16 PoE+ (380W)	1 internal PSU, fixed	2

Software at a Glance

LAYER 2+ / LAYER 3 LITE FEATURES							
Management	IPv4/IPv6 ACL and QoS	IPv4/IPv6 Multicast Filtering	G.8032 ERPS STP/RSTP/MSTP	IEEE (802.3az) Energy Efficient Ethernet	VLANs	Convergence	IPv4 & IPv6 Static Routing
Web Browser-based GUI (HTTP/HTTPS), PC-Based Smart Control Center Utility (SCC) , RMON, SNMP	L2, L3, L4, ingress	IGMP and MLD Snooping	Yes	Yes	Static Dynamic, Voice, MAC, Protocol-based	LLDP-MED, RADIUS, 802.1X	Yes

Performance at a Glance

Model Name	Packet buffer	CPU	ACLs	MAC Address Table ARP Table VLANs	Fabric	Latency (Max Connection Speed)	Static Routes (IPv4 & IPv6)	Multicast IGMP Group
SP7500-16PGE4GC-L2M	12MB	Dual-Core 512GHz MIPS InterAptive CPU subsystem 1GB DDR RAM	100 shared	8K MAC 512 ARP 4K VLANs QinQ	128Gbps 36Mpps line-rate	1G Copper: <3.35µs 1G Fiber: <2.5µs	IPv4: 100 IPv6: 100	512
SP7500-16PGE4GC-400W-L2M								



Features and Benefits

Hardware Features	
1000BASE-T Copper Ethernet PoE+ connections	Support high-density VoIP, Surveillance and Wi-Fi AP deployments, scal-able for future growth. Never face the risk of running out of PoE ports.
1GBASE-X Fiber SFP ports	Four dedicated 1Gb SFP ports for aggregation to the network core. Support for Fiber and Copper modules. Can also build dual redundancy by a trunked uplink with link aggregation.
Great choice of PoE port counts and PoE power budgets that can adapt to the business's needs	280W/380W PoE budget available across 16 Gigabit PoE+ ports (802.3af/at) – Connect multiple power demanding devices to your network with a single wire for power and connectivity.
Energy Efficient Ethernet (IEEE 802.3az)	Maximum power reduction for onging operational cost savings.
Software Features	
Comprehensive IPv6 Support for Management, ACL and QoS	Build current network with future in mind. Ensure investment protection and a smooth migration to an IPv6-based network without switch replacement.
IPv4 & IPv6 Static Routing	A simple way to provide segmentation of the network with internal routing through the switch – reserving the router for external traffic routing only, making the entire network more efficient.
Robust security features: <ul style="list-style-type: none"> • 802.1x authentication (EAP) • Port-based security by locked MAC • ACL filtering to permit or deny traffic based on MAC and IP addresses 	Build a secured, converged network with all types of traffic by preventing external attacks and blocking malware while allowing secure access for authorized users.
Comprehensive QoS features: <ul style="list-style-type: none"> • Port-based or 802.1p-based prioritization • Layer 3-based (DSCP) prioritization • Port-based ingress and egress rate limiting 	Advanced controls for optimized network performance and better delivery of mission-critical traffic such as voice and video.
IGMP (IPv4) and MLD (IPv6) Snooping and Querier modes with Fast Leave	Facilitate fast receiver joins and leaves for multicast streams. Save cost and improve network efficiency by ensuring multicast traffic only reaches desig-nated receivers without the need of an extra multicast router.

Target Application

Network Convergence

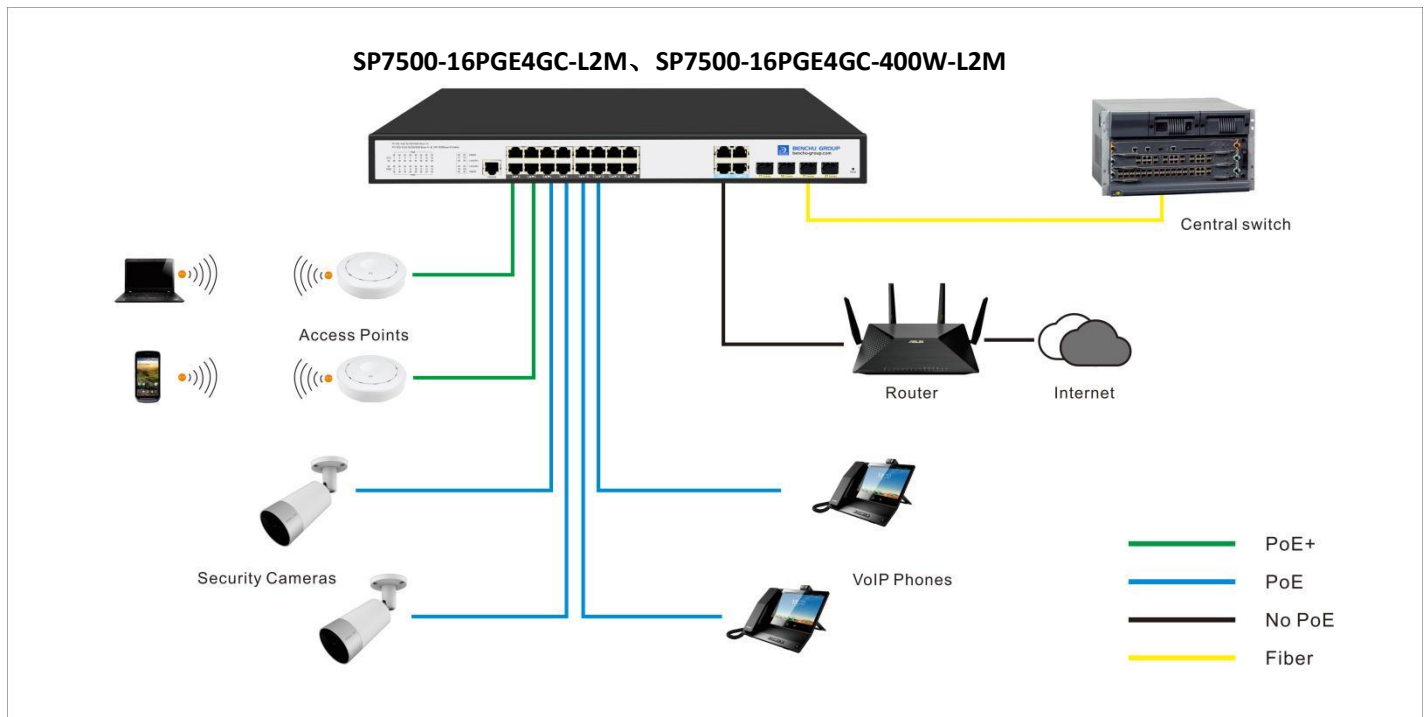

Within small and medium-sized organizations — especially in the hospitality, catering, education, and retail industries — there is growing deployment of VoIP phones, IP security cameras, video-over-IP endpoints, proximity sensors, LED lighting, secure access door locks, and other IoT devices. The dense proximity of these devices requires network switches capable of supporting PoE so a network manager can add power-hungry devices to the network with a single wire for power AND connectivity. Wave 2 802.11ac wireless access points and pan-tilt-zoom HD surveillance cameras with features such as night vision and built-in motion tracking also require PoE+ power (802.3at), increasing the power demands on PoE switches.

The new 16-port BENCHU GROUP Smart Switches support dense deployments of these modern high-power PoE+ devices. They offer powerful Layer 2 and Layer 3 features for IPv4 and IPv6 with enhanced performance and a focus on usability within SMB environments:

- 280W (SP7500-16PGE4GC-L2M) PoE budget across 16 Gigabit PoE+ ports
- 380W (SP7500-16PGE4GC-400W-L2M) PoE budget across 16 Gigabit PoE+ ports
- 4 dedicated 1.25G SFP fiber ports or RJ45 for aggregation to the network core
- Layer 3 static routing (IPv4 and IPv6) for interVLAN local routing
- IGMP Snooping, IGMP Querier and IGMP Fast Leave for multicast optimization
- ERPS(G.8032) STP/FSTP/MSTP for Ring network and Link protection
- Include VLANs, PoE scheduling, ACLs, DiffServ, LACP, MVR and DHCP
- Easy-to-use Web browser-based management GUI — No need for an IT expert
- Limited Lifetime* Warranty, Tech support

Structure Diagrams

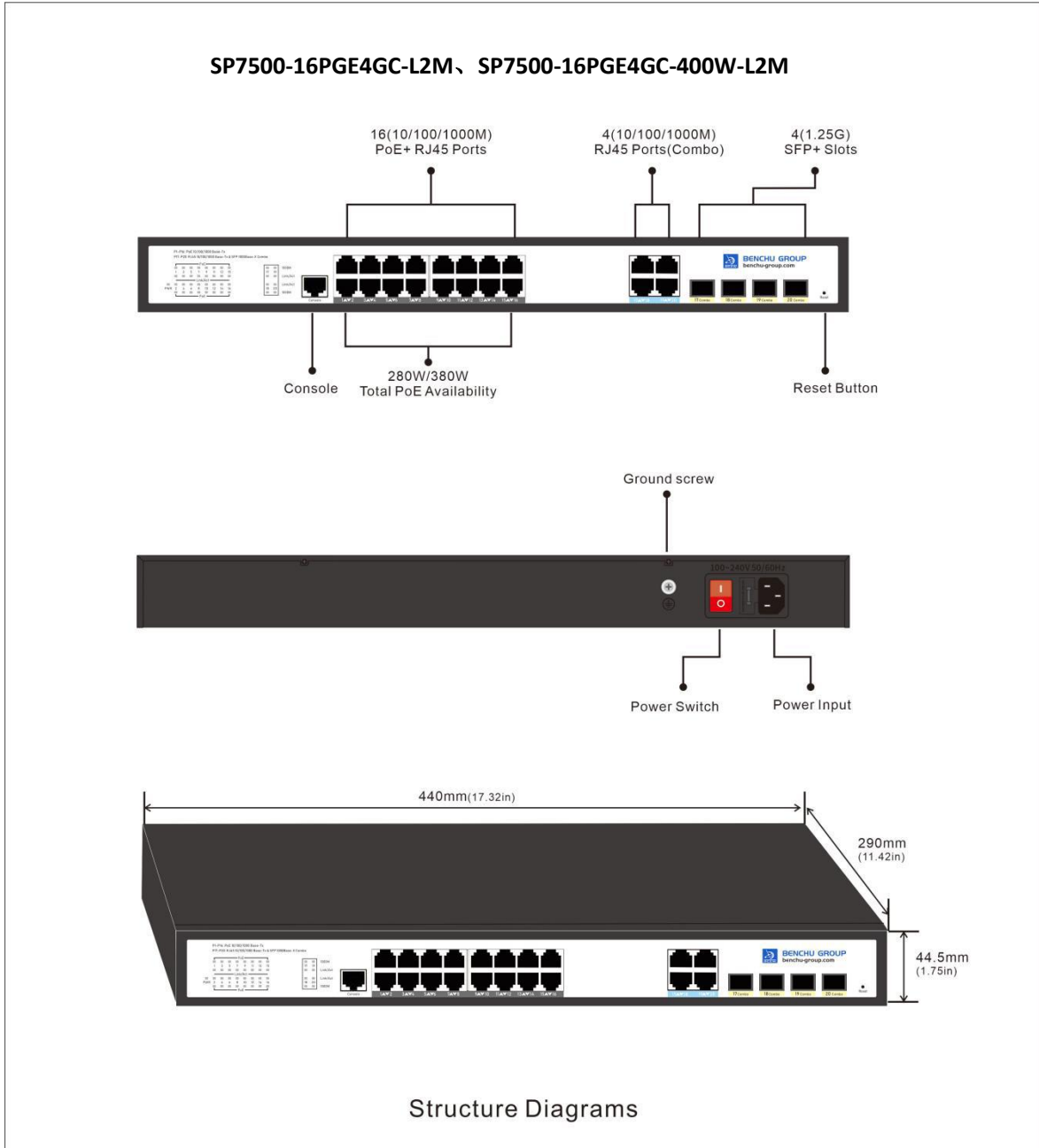



Technical Specifications	SP7500-16PGE4GC-L2M	SP7500-16PGE4GC-400W-L2M
10M/100M/1000M RJ-45 copper ports		16
PoE / PoE+ ports	16 (280W PoE budget)	16 (380W PoE budget)
1.25G SFP (fiber) ports uplink		4
1000M RJ-45 copper ports uplink		4 (Combo)
Console Port (For config)		Yes
Performance Specification		
CPU	Dual-Core 512GHz MIPS InterAptive CPU subsystem	
Packet buffer memory (Dynamically shared across only used ports)		8Mb
Forwarding modes	Store-and-forward	
Bandwidth	128 Gbps	
Priority queues	8	
MAC address database size (48-bit MAC addresses)	8K	
Multicast groups	512K	
Number of IPv4 static routes	100	
Number of IPv6 static routes	100	
Number of VLANs	4094	
Number of VLANs(Open QinQ)	16,760,836(4094*4094)	
Number of ARP cache entries	512 ARP	
Number of DHCP snooping bindings	256	
Access Control Lists (ACLs)	100 shared for MAC, IP and IPv6 ACLs (ingress)	
Packet forwarding rate (64 byte packet size) (Mpps)	35.72Mpps	
Jumbo frame support (bytes)	Up to 9K packet size	
Mean Time Between Failures (MTBF) @ 25°C	135,226 hours	
100M Copper Latency (64-byte; 1518-byte; 9216-byte frames)	8.321μs; 8.403μs; 8.449μs	
1G Copper Latency (64-byte; 1518-byte; 9216-byte frames)	3.506μs; 3.541μs; 3.615μs	
1G Fiber Latency (64-byte; 1518-byte; 9216-byte frames)	2.978μs; 3.118μs; 3.176μs	



L2 Services - VLANs	SP7500-16PGE4GC-L2M	SP7500-16PGE4GC-400W-L2M
IEEE 802.1Q VLAN tagging		Yes
QinQ VLAN tagging		Yes
IP-based VLANs		Yes
MAC-based VLANs		Yes
Protocol-based VLAN		Yes
Voice VLAN		Yes
VLAN mapping		Yes
L2 Services - Availability		
Broadcast, multicast, unknown unicast storm control		Yes
IEEE 802.3ad - LAGs (LACP)		Yes
IEEE 802.3x (full duplex and flow control)		Yes
IEEE 802.1D Spanning Tree Protocol		Yes
IEEE 802.1w Rapid Spanning Tree Protocol		Yes
IEEE 802.1s Multiple Spanning Tree Protocol		Yes
ITU-TG.8032 (ERPS)		Yes, Recovery time < 50ms
L2 Services - Multicast Filtering		
IGMP snooping (v1, v2 and v3)		Yes
MLD snooping support (v1 and v2)		Yes
IGMP snooping querier (v2)		Yes
MLD snooping querier (v1)		Yes
Multicast VLAN Registration (MVR)		Yes
L3 Services - DHCP		
DHCP client		Yes
DHCP snooping		Yes
DHCP server		Yes
L3 Services - Routing		
IPv4 static routing		100
IPv6 static routing		100



Link Aggregation	SP7500-16PGE4GC-L2M	SP7500-16PGE4GC-400W-L2M
IEEE 802.3ad - LAGs (LACP)		Yes
Manual LAG		Yes
# of LAGs / # of members in each LAG		8 LAGs with max 8 members in each LAG
Network Monitoring and Discovery Services		
802.1ab LLDP		Yes
SNMP		v1, v2c, v3
RMON group 1,2,3,9		Yes
Network Security		
IEEE 802.1x		Yes
RADIUS accounting		Yes
Access Control Lists (ACLs)		Yes
IP-based ACLs (IPv4 and IPv6)		L2 / L3 / L4
MAC-based ACLs		Yes
TCP/UDP-based ACLs		Yes
Control MAC # static entries		48
Port-based security by locked MAC addresses		Yes
Dynamic ARP inspection		Yes
Quality of Service (QoS)		
Port-based rate limiting		Yes ingress and egress
Port-based QoS		Yes
Support for IPv6 fields		Yes
DiffServ QoS		Yes ingress
IEEE 802.1p COS		Yes
Destination MAC and IP		Yes
Weighted Round Robin (WRR)		Yes
Strict priority queue technology		Yes
Rata limit		Yes



IEEE Network Protocols	SP7500-16PGE4GC-L2M	SP7500-16PGE4GC-400W-L2M
<ul style="list-style-type: none"> • IEEE 802.3 Ethernet • IEEE 802.3u 100BASE-T • IEEE 802.3ab 1000BASE-T • IEEE 802.3z 1000BASE-SX/LX • IEEE 802.3af PoE • IEEE 802.3at PoE+ • IEEE 802.3az Energy Efficient Ethernet (EEE) • IEEE 802.3ad Trunking (LACP) 	<ul style="list-style-type: none"> • IEEE 802.3x Full-Duplex Flow Control • IEEE 802.1Q VLAN Tagging • IEEE 802.1AB LLDP with ANSI/TIA-1057 (LLDP-MED) • IEEE 802.1p Class of Service • IEEE 802.1D Spanning Tree (STP) • IEEE 802.1s Multiple Spanning Tree (MSTP) • IEEE 802.1w Rapid Spanning Tree (RSTP) • ITU-TG.8032 Ethernet Ring Protection Switching (ERPS) • IEEE 802.1x RADIUS Network Access Control 	
Management, Monitoring & Troubleshooting		
Password management		Yes
Admin access control via RADIUS and TACACS+		Yes
IPv6 management		Yes
SNMP v1/v2c/v3		Yes
RMON group 1,2,3,9		Yes
Port mirroring		Yes ingress and egress
Many-to-one port mirroring		20
Cable test utility		Yes
TLS/HTTPS Web-based access (version)		Yes (v1.2)
File transfers (uploads, downloads)		TFTP / HTTP
HTTP upload/download (firmware)		Yes
LEDs		Yes
Per port		Speed, Link, Activity; or PoE in different mode
Per device		Power, system
Physical Specifications		
Dimensions	440 x 290 x 44.5 mm (17.32 x 11.42 x 1.75 in)	
Weight	3.9 kg (8.6 lb)	4.3 kg (9.48 lb)
Power Requirements	AC 100~240V 50/60Hz	
Power Consumption (when all ports used, line-rate traffic and max PoE)	300W	400W
Max power (worst case, all ports used, full PoE, line-rate traffic) (Watts)	17W	20W
Idle power consumption (all ports link-down standby) (Watts)	15W	
Energy Efficient Ethernet (EEE) IEEE 802.3az	Yes (deactivated by default)	
Fan	2 Fans	



Environmental Specifications	SP7500-16PGE4GC-L2M	SP7500-16PGE4GC-400W-L2M
Operating		
Operating Temperature	-20° to 50°C (-4° to 122°F)	
Humidity	90% maximum relative humidity (RH), non-condensing	
Altitude	10,000 ft (3,000 m) maximum	
Storage		
Storage Temperature	-20° to 70°C (-4° to 158°F)	
Humidity (relative)	95% maximum relative humidity, non-condensing	
Altitude	10,000 ft (3,000 m) maximum	
Electromagnetic Emissions and Immunity		
Certifications	CE mark, commercial	
	FCC Part 15 Class A, VCCI Class A	
	Class A EN 55022 (CISPR 22) Class A	
	Class A C-Tick	
	EN 55024	
	CCC	
47 CFR FCC Part 15, SubpartB, Class A ICES-003: 2016 Issue 6, Class A		
ANSI C63.4:2014		
IEC 60950-1:2005 (ed.2)+A1:2009+A2:2013 AN/NZS CISPR 22:2009+A1:2010 CLASS A		
Safety		
Certifications	CB mark, commercial	
	CSA certified (CSA 22.2 #950)	
	EN 60950-1: 2006 + A11:2009 + A1:2010 + A12:2011 + A2:2013 IEC 60950-1:2005 (ed.2)+A1:2009+A2:2013	
	AN/NZS 60950.1:2015	
	CCC (China Compulsory Certificate)	
Warranty and Support		
Hardware Limited Warranty	Limited Lifetime*	
Technical Support via Phone and Email*	Limited Lifetime*	
Limited Lifetime* 24x7 Online Chat Technical Support	Limited Lifetime*	
Package Contents		
All models	Smart PoE Managed Switch	
	AC Power cord with C13 connector (localized to region of sale)	
	Brackets and screws for rack mounting	
	Rubber protection caps, which are already installed in the SFP sockets Installation guide	
	User's manual	

